

18F-B推入式继电器系列

PUSH-IN RELAY SERIES

超过30年的领先技术经验，致力于成为世界领先的继电器制造商

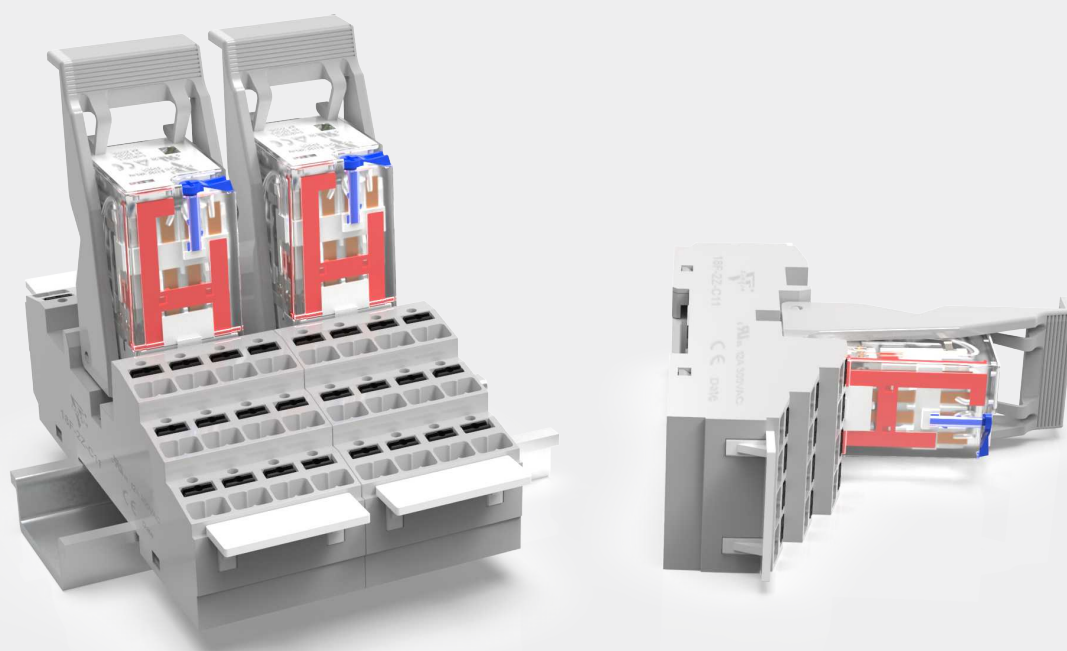

推入式继电器模组



PUSH-IN RELAY MODULE
18F、157F、14F、41F SERIES

推入式继电器插座 Push-in socket

● 推入式技术 Push-in technology

减少控制面板工作的新标准，结合了多种继电器和易于使用的功能，采用 Push-In Plus 技术的插座系列可减少接线和工作量。

A New Standard for Reducing Work in Control Panel, Combining a Wide Selection of Relays with the Easy-to-use, Sockets with Push-In Plus technology Series Reduces Wiring and Workload.



● 14F-2P 连接桥 Way jumper link

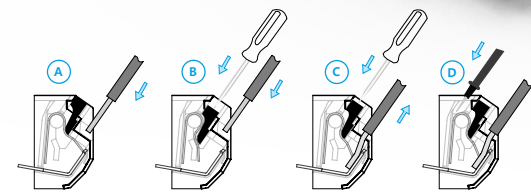

快速简便的跳线能够连接在不同类型的接口模块

Fast and easy connection with jumper links - able to interconnect between different types of interface modules.

推入式端子允许快速连接的电线插入端台，实心电线或套圈进入终点站，可以通过先向下按用螺丝刀或手指按按钮。对于绞合电缆，首先使用按钮打开端子，用于抽出以及插入。

The Push-in terminals permit the quick connection of solid wires or ferrules by their simple insertion into the terminal. It is possible to open the terminal to extract the wire by first pushing down on the push-button using a screwdriver or fingers. For stranded cable it is necessary first to open the terminal using the push button, both for the extraction and insertion.

适配器允许轻松连接 A1/A2 端子最多 8 个 适配器模块通过一个 PLC 输出 14 极电缆，加上简单 2 线电源连接。

The MasterADAPTER permits the easy connection of A1/A2 terminals of up to 8 MasterINTERFACE modules to PLC outputs via a 14-Pole cable, plus simple 2-wire power supply connection.

● JH-AR 适配器 Master Adapter

● 41F-T 标识牌 Signage



标记标签架 - 所用标签可用热转印机的标签，可提高能见度和易读性。

The marker tag holder - for tags that can be used with thermal transfer printers - has also been redesigned for improved visibility and legibility.

● 41F-JR

● 41F-J1

● 41F-JB

● 连接桥 Way jumper link

使用跳线快速简便地连接链接 - 能够相互连接不同类型的接口模块。

Fast and easy connection with jumper links - able to interconnect between different types of interface modules.

● S9-PI 连接桥 Way jumper link

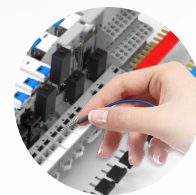

宏的 Push-In Plus 技术就像插入耳机插孔一样简单到。

它们有助于减少工作量和提高布线质量。

JINHONG' s Push-In Plus technology are as easy as inserting to an earphone jack. They help reduce the work load and improve wiring quality.



所有采用 Push-In Plus 技术的插座都随附标配释放杆，方便接力锁定和释放。

All Sockets with Push-In Plus technology come with release levers as standard for easy Relay locking and releasing.

■ 无需工具即可安装和拆下继电器和底座，操作简单快速
The relay and base can be installed and removed without tools, and the operation is simple and fast.

■ 继电器
Relay

ZJ18FT-4P

■ 塑料挂钩
Plastic hook

18F-S36

■ 指示灯
Indicator light

■ 红色: 交流 / Red: AC
■ 绿色: 直流 / Green: DC

■ 写字板
Maker

18F-T
用于粘贴和记号标识,方便后续查找检查

It is used for pasting and marking identification to facilitate subsequent search and inspection

■ 继电器插座
Relay Socket

18F-4Z-C11
提供两款颜色可选,满足不同使用场景,不同客户需求

Two colors are available to meet different use scenarios and customer needs

■ 黑色 / Black
■ 灰色 / Grey

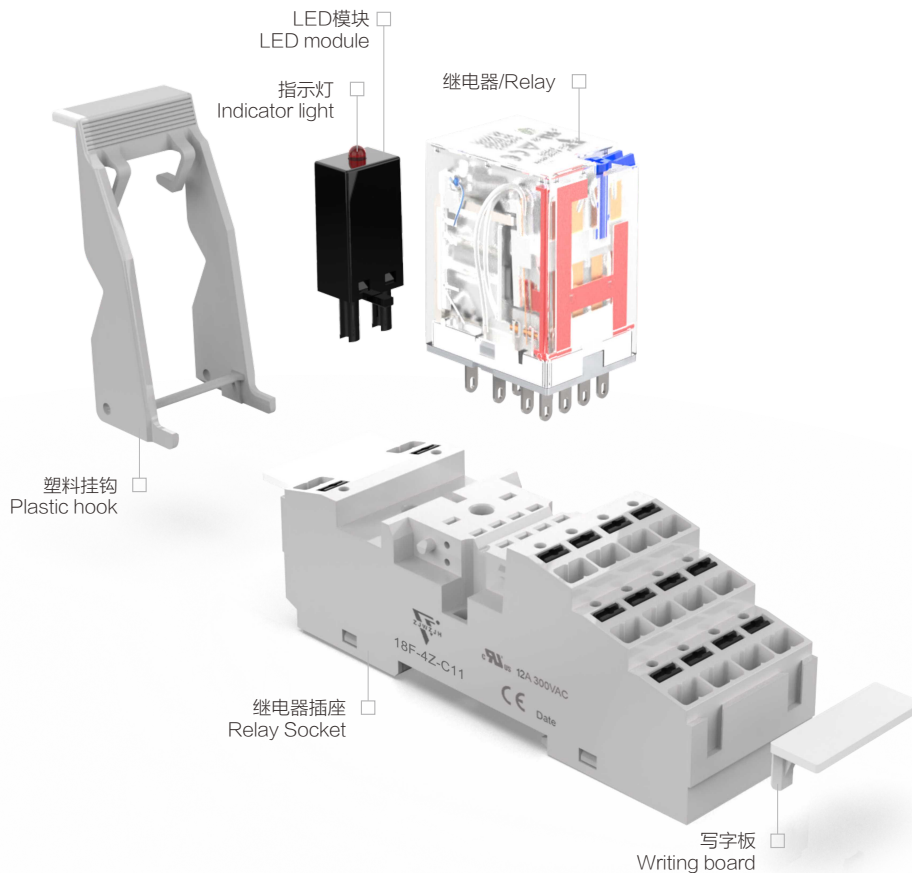

继电器型号命名/ Relay Select Code

ZJ18F	T	-	2P	L	D	1	H	B /	A230	R
型号 Type	测试按钮 Test button	触点形式 Contact arrangement	发光二极管 LED	线圈保护 Coil Protection	安装方式 Mounting Termination	触点负载电流 Coil Protection	带上盖 With lid	线圈电压 Coil voltage	线圈正负极 Positive and negative coil	
无: 不带测试按钮 T: 带测试按钮 Nil: Without test button T: With test button	2P: 2组转换 3P: 3组转换 4P: 4组转换 2P: 2 Form C 3P: 3 Form C 4P: 4 Form C	无: 不带LED L: 带LED Nil: Without LED L: With LED	无: 不带电子元件 D: 带整流二极管 C: 带压敏电阻 Nil: Without electronic components D: With rectifier diode C: With varistor	无: 插座式安装 1: 印制板安装 Nil: Socket Mounting 1: PCB Mounting	无: 2/3P 6.6A 4P 5A H: 2/3P 10A Nil: 2/3P 6.6A 4P 5A H:2/3P 10A	无: 不带上盖 B: 带上盖 Nil: Without lid B: With lid	006~110: 6~110VDC A006~A240: 6~240VAC	无: 13(-) 14(+) R: 13(+) 14(-) Nil: 13(-) 14(+) R: 13(+) 14(-)		

可插拔继电器/ Interface Relay-pluggable

ZJ18F-2PB



技术参数/ Technical Data

型号 Type	ZJ18F-2PB	
触点形式 Contact arrangement	2P	2P大电流
触点材料 Contact material	Ag alloy	
负载 Load		
-阻性 Impedance	6.6A 250VAC/30VDC	10A 250VAC/30VDC
额定电压 Rated voltage	250VAC/30VDC	
吸合电压 And the voltage	DC: ≤ 75%, AC: ≤ 80% (额定电压)	
释放电压 The release of the voltage	DC: ≥ 10%, AC: ≥ 30% (额定电压)	
接触电阻 Initial Contact resistance	≤ 100mΩ	≤ 50mΩ
电气寿命 Electrical endurance	1x10 ⁵ 次	
机械寿命 Mechanical endurance	1x10 ⁷ 次	

性能参数/ Characteristics

动作时间 Operating time(at rated voltage)	≤ 20ms			
释放时间 Release time	≤ 20ms			
温度范围 Ambient temperature(at rated voltage)	-40°C~+70°C			
线圈功率 Coil power	DC: ~0.9W ; AC: ~1.2VA			
环境湿度 Environmental humidity	5%~85%RH			
大气压力 The atmospheric pressure	86~106KPa			
封装方式 Packaging method	防尘罩型 Dust protected			
重量 Weight	~35g			
初始耐压 Test voltage				
-同极触点间 With a contacts	1000VAC	50/60Hz	1Min	漏电流
-异极触点间 Heteropolar contact	2000VAC	50/60Hz	1Min	漏电流
-线圈和触点间 Contacts coil	2000VAC	50/60Hz	1Min	漏电流
耐冲击 Shock resistance	1000m/s ²			
耐振动 Vibration resistance	10~55Hz 双振幅: 1.0mm			
绝缘电阻 Insulation resistance	≥ 1000MΩ (500VDC)			

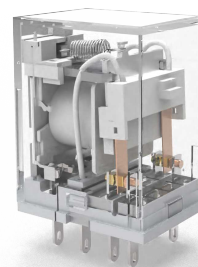

Fig.1. 接线图/ Wiring Diagram

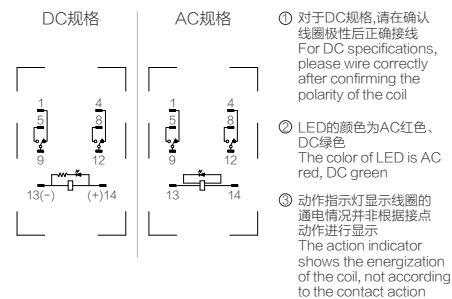

Fig.2. 耐久性曲线/ Endurance Curve

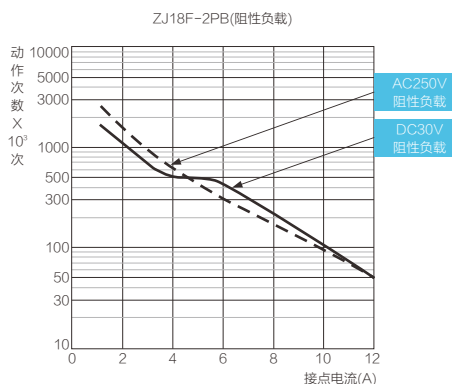
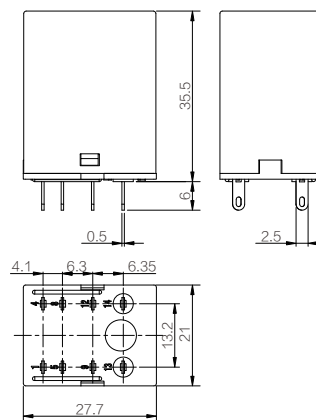

Fig.3. 外形尺寸图/ Dimensions



认证/ Standards



可插拔继电器/ Interface Relay-pluggable

ZJ18FT-2PB



技术参数/ Technical Data

型号 Type	ZJ18FT-2PB	
触点形式 Contact arrangement	2P	2P大电流
触点材料 Contact material	Ag alloy	
负载 Load		
-阻性 Impedance	6.6A 250VAC/30VDC	10A 250VAC/30VDC
额定电压 Rated voltage	250VAC/30VDC	
吸合电压 And the voltage	DC: ≤ 75%, AC: ≤ 80% (额定电压)	
释放电压 The release of the voltage	DC: ≥ 10%, AC: ≥ 30% (额定电压)	
接触电阻 Initial Contact resistance	≤ 100mΩ	≤ 50mΩ
电气寿命 Electrical endurance	1x10 ⁵ 次	
机械寿命 Mechanical endurance	1x10 ⁷ 次	

性能参数/ Characteristics

动作时间 Operating time(at rated voltage)	≤ 20ms			
释放时间 Release time	≤ 20ms			
温度范围 Ambient temperature(at rated voltage)	-40°C~+70°C			
线圈功率 Coil power	DC: ~0.9W ; AC: ~1.2VA			
环境湿度 Environmental humidity	5%~85%RH			
大气压力 The atmospheric pressure	86~106KPa			
封装方式 Packaging method	防尘罩型 Dust protected			
重量 Weight	~35g			
初始耐压 Test voltage				
-同极触点间 With a contacts	1000VAC	50/60Hz	1Min	漏电流
-异极触点间 Heteropolar contact	2000VAC	50/60Hz	1Min	漏电流
-线圈和触点间 Contacts coil	2000VAC	50/60Hz	1Min	漏电流
耐冲击 Shock resistance	1000m/s ²			
耐振动 Vibration resistance	10~55Hz 双振幅: 1.0mm			
绝缘电阻 Insulation resistance	≥ 1000MΩ (500VDC)			



Fig.1. 接线图/ Wiring Diagram

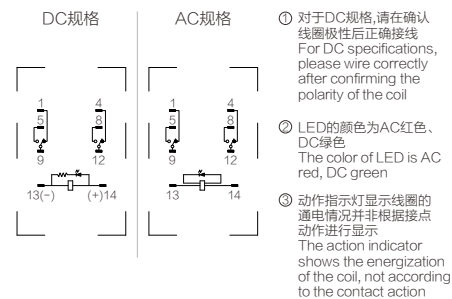

Fig.2. 耐久性曲线/ Endurance Curve

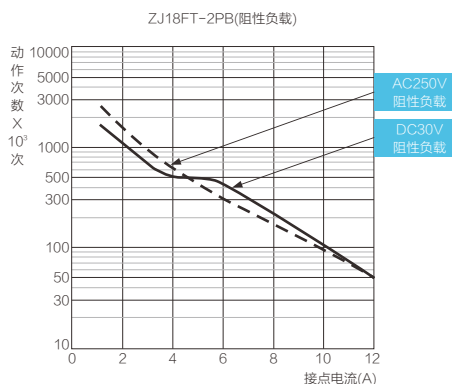
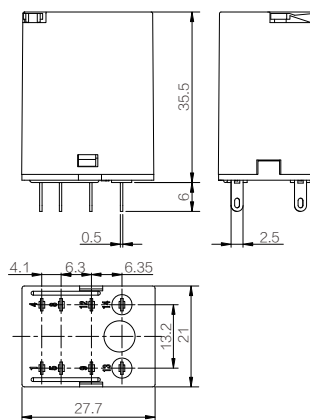

Fig.3. 外形尺寸图/ Dimensions



认证/ Standards



Push-In 插座/ Relay Socket | Push-In

18F-2Z-C11



型号 Type	18F-2Z-C11
额定负载 Nominal load	
-电流 Current	12A
-电压 Voltage	300V
介质耐压 Dielectric strength	2500V/min
剥线长度 Stripping length	7mm
适用导线截面积 Wire cross section	
-单根导线 Single wire	2x2.5mm ²
-套管导线 Casing wire	2x1.5mm ²
弹片锁紧力 Clamping force	≥60
使用环境 Ambient temperature	-25°C~+85°C

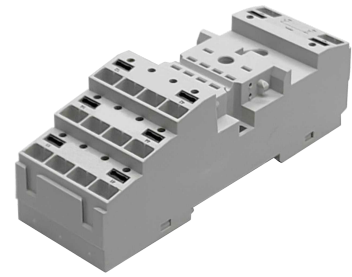

附件 Accessories

18F连接桥/Bridge



可选颜色 / Selective Color
 ■ 红色 / Red
 ■ 黄色 / Blue
 ■ 黑色 / Black
 ■ 灰色 / Grey

规格/specifications: 18F-2P-27.8

36mm塑料单鼻头挂钩/Plastic single nose retainer



规格/specifications: 18F-S36

18F写字板/Marker

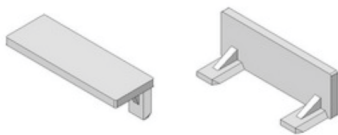

规格/specifications: 18F-T

连接桥/Bridge



规格/specifications: S9-PI

Fig.1. 接线图/ Wiring Diagram

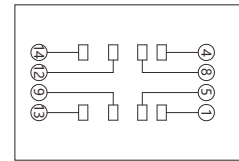
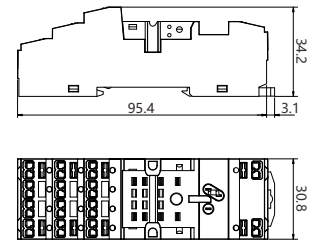

Fig.2. 尺寸图/ Dimensions (mm)



认证/ Standards



可插拔继电器/ Interface Relay-pluggable

ZJ18F-4PB



技术参数/ Technical Data

型号 Type	ZJ18F-4PB
触点形式 Contact arrangement	4P
触点材料 Contact material	Ag alloy
负载 Load	
-阻性 Impedance	5A 250VAC/30VDC
额定电压 Rated voltage	250VAC/30VDC
吸合电压 And the voltage	DC: ≤ 75%, AC: ≤ 80% (额定电压)
释放电压 The release of the voltage	DC: ≥ 10%, AC: ≥ 30% (额定电压)
接触电阻 Initial Contact resistance	≤ 100mΩ
电气寿命 Electrical endurance	1x10 ⁵ 次
机械寿命 Mechanical endurance	1x10 ⁷ 次

性能参数/ Characteristics

动作时间 Operating time(at rated voltage)	≤ 20ms
释放时间 Release time	≤ 20ms
温度范围 Ambient temperature(at rated voltage)	-40°C~+70°C
线圈功率 Coil power	DC: ~0.9W ; AC: ~1.2VA
环境湿度 Environmental humidity	5%~85%RH
大气压力 The atmospheric pressure	86~106KPa
封装方式 Packaging method	防尘罩型 Dust protected
重量 Weight	~35g
初始耐压 Test voltage	
-同极触点间 With a contacts	1000VAC 50/60Hz 1Min 漏电流
-异极触点间 Heteropolar contact	2000VAC 50/60Hz 1Min 漏电流
-线圈和触点间 Contacts coil	2000VAC 50/60Hz 1Min 漏电流
耐冲击 Shock resistance	1000m/s ²
耐振动 Vibration resistance	10~55Hz 双振幅: 1.0mm
绝缘电阻 Insulation resistance	≥ 1000MΩ (500VDC)

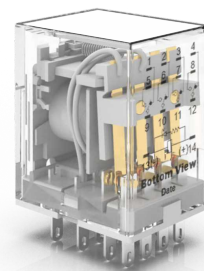

Fig.1. 接线图/ Wiring Diagram

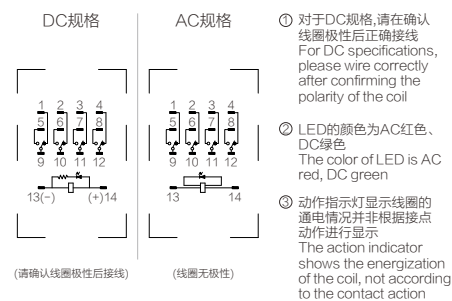

Fig.2. 耐久性曲线/ Endurance Curve

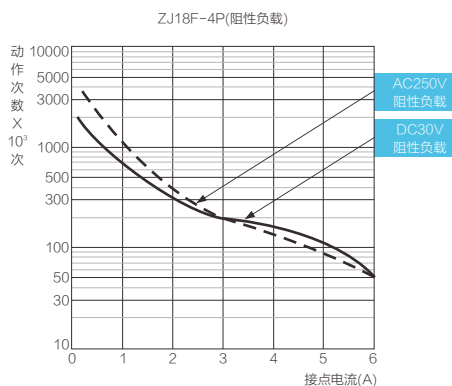
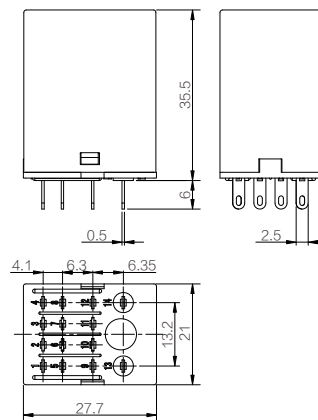

Fig.3. 外形尺寸图/ Dimensions



认证/ Standards



可插拔继电器/ Interface Relay-pluggable

ZJ18FT-4PB



技术参数/ Technical Data

型号 Type	ZJ18FT-4PB
触点形式 Contact arrangement	4P
触点材料 Contact material	Ag alloy
负载 Load	
-阻性 Impedance	5A 250VAC/30VDC
额定电压 Rated voltage	250VAC/30VDC
吸合电压 And the voltage	DC: ≤ 75%, AC: ≤ 80% (额定电压)
释放电压 The release of the voltage	DC: ≥ 10%, AC: ≥ 30% (额定电压)
接触电阻 Initial Contact resistance	≤ 100mΩ
电气寿命 Electrical endurance	1x10 ⁵ 次
机械寿命 Mechanical endurance	1x10 ⁷ 次

性能参数/ Characteristics

动作时间 Operating time(at rated voltage)	≤ 20ms
释放时间 Release time	≤ 20ms
温度范围 Ambient temperature(at rated voltage)	-40°C~+70°C
线圈功率 Coil power	DC: ~0.9W ; AC: ~1.2VA
环境湿度 Environmental humidity	5%~85%RH
大气压力 The atmospheric pressure	86~106KPa
封装方式 Packaging method	防尘罩型 Dust protected
重量 Weight	~35g
初始耐压 Test voltage	
-同极触点间 With a contacts	1000VAC 50/60Hz 1Min 漏电流
-异极触点间 Heteropolar contact	2000VAC 50/60Hz 1Min 漏电流
-线圈和触点间 Contacts coil	2000VAC 50/60Hz 1Min 漏电流
耐冲击 Shock resistance	1000m/s ²
耐振动 Vibration resistance	10~55Hz 双振幅: 1.0mm
绝缘电阻 Insulation resistance	≥ 1000MΩ (500VDC)

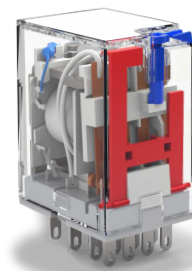

Fig.1. 接线图/ Wiring Diagram

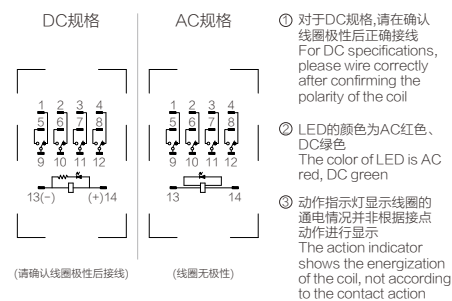

Fig.2. 耐久性曲线/ Endurance Curve

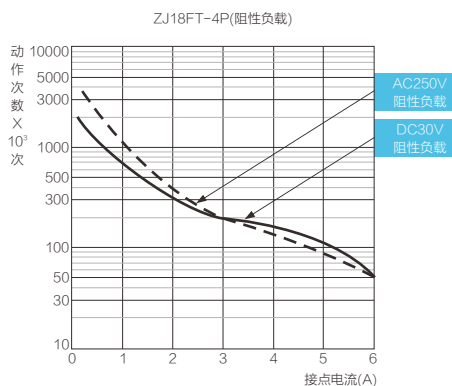
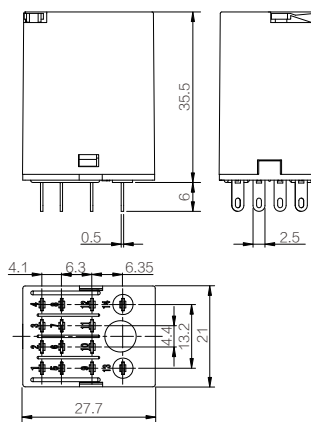

Fig.3. 外形尺寸图/ Dimensions



认证/ Standards



Push-In 插座/ Relay Socket | Push-In

18F-4Z-C11



型号 Type	18F-4Z-C11
额定负载 Nominal load	
-电流 Current	8A
-电压 Voltage	300V
介质耐压 Dielectric strength	2500V/min
剥线长度 Stripping length	8mm
适用导线截面积 Wire cross section	
-单根导线 Single wire	2x2.5mm ²
-套管导线 Casing wire	2x1.5mm ²
弹片锁紧力 Clamping force	≥60
使用环境 Ambient temperature	-25°C~+85°C

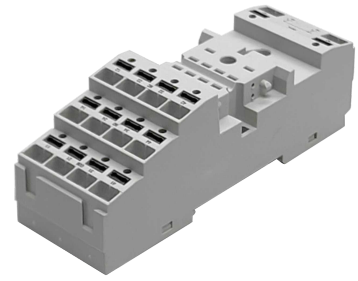

附件 Accessories

18F连接桥/Bridge



- 可选颜色 / Selective Color
- 红色 / Red
 - 黄色 / Blue
 - 黑色 / Black
 - 灰色 / Grey

规格/specifications: 18F-2P-27.8

36mm塑料单鼻头挂钩/Plastic single nose retainer



规格/specifications: 18F-S36

18F写字板/Marker

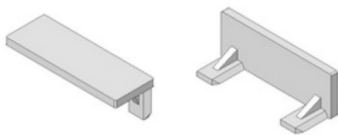

规格/specifications: 18F-T

连接桥/Bridge



规格/specifications: S9-PI

Fig.1. 接线图/ Wiring Diagram

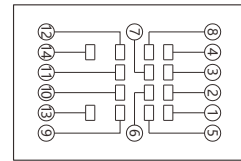
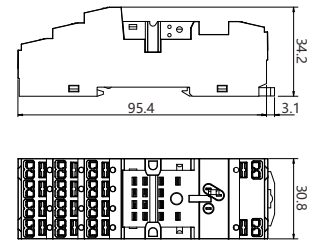

Fig.2. 尺寸图/ Dimensions (mm)



认证/ Standards





本文件已打印在生态纸上
Printing with environmentally friendly paper



本手册属温州金宏电器有限公司印制，仅用于说明本系列产品的相关信息。金宏电器可能因技术升级或采用更新的生产工艺而改进手册有关内容，或对本手册的印刷错误及不准确的信息进行必要的改进和更改，恕不另行通知。商家订货时请联系公司，以证实相关信息。

This manual is intended for on-site installation and product use by Jinhong Electric(KINRED) Please retain the technical documentation and drawings for future reference.

For detailed information regarding this manual, please contact the relevant department or our customer service. Specifications are subject to change without prior notice.

本公司已完成宣传文案整改，所有业务资料均以现行最新版目录为准，旧版作废。

We have revised non-compliant wording in old catalogs. The latest version shall prevail; all previous versions are invalid.



温州金宏电器有限公司
WENZHOU JINHONG ELECTRICAL APPLIANCE CO., LTD

更专业的技术服务



www.wzjh.cc



T +86-577-57187518
F +86-577-57187788
E admin@wzjh.cc

Address

浙江省乐清市城东产业功能区永兴二路10号
Yongxing second Road 10#, Chengdong industrial functional area, Yueqing city, Zhejiang Province.